

HSM-38/3S
HEATED SHELF MERCHANDISER



- Three-shelf merchandiser incorporates thermal kinetic glass technology to provide three evenly heated display surfaces.
- Packaged foods are held at safe temperatures to offer quality holding on each of the three independently controlled shelves.
- Low wattage fluorescent lighting at the top of each shelf enhances the display while the glass shelves provide the low power usage of kinetic energy.
- Vertical display maximizes packaged product capacity in a small linear footprint while the glass side panels offer greater product visibility from both sides of each illuminated shelf.

The multi-shelf merchandiser includes heavy-duty, non-magnetic stainless steel construction throughout. Each of the three (3) shelves are controlled by one (1) adjustable thermostat with a range of 0 to 10, and includes one (1) heat-on indicator light. The controls are protected by a sliding panel on the front of the merchandiser. Two (2) shelves are angled at 8° for visibility, and include one (1) warm-light fluorescent above each shelf. The bottom shelf is flat. Front mounted heat-guards provide customer protection. Solar cool, bronze side glass reflects heat back into the product area and mirrors the display to enhance the merchandising effect. Stainless steel front panel and black laminate end panels are standard.

MODEL HSM-38/3S: Three-tier, self-service merchandiser, 38" (965mm) width



ADDITIONAL FEATURES & OPTIONS

- Front Panel
 - ➔ Specify color choice:
 - Stainless Steel, standard
 - Black, optional, CONTACT FACTORY FOR QUOTE
 - Burgundy, optional, CONTACT FACTORY FOR QUOTE

HSM-38/3S

HEATED SHELF MERCHANDISER

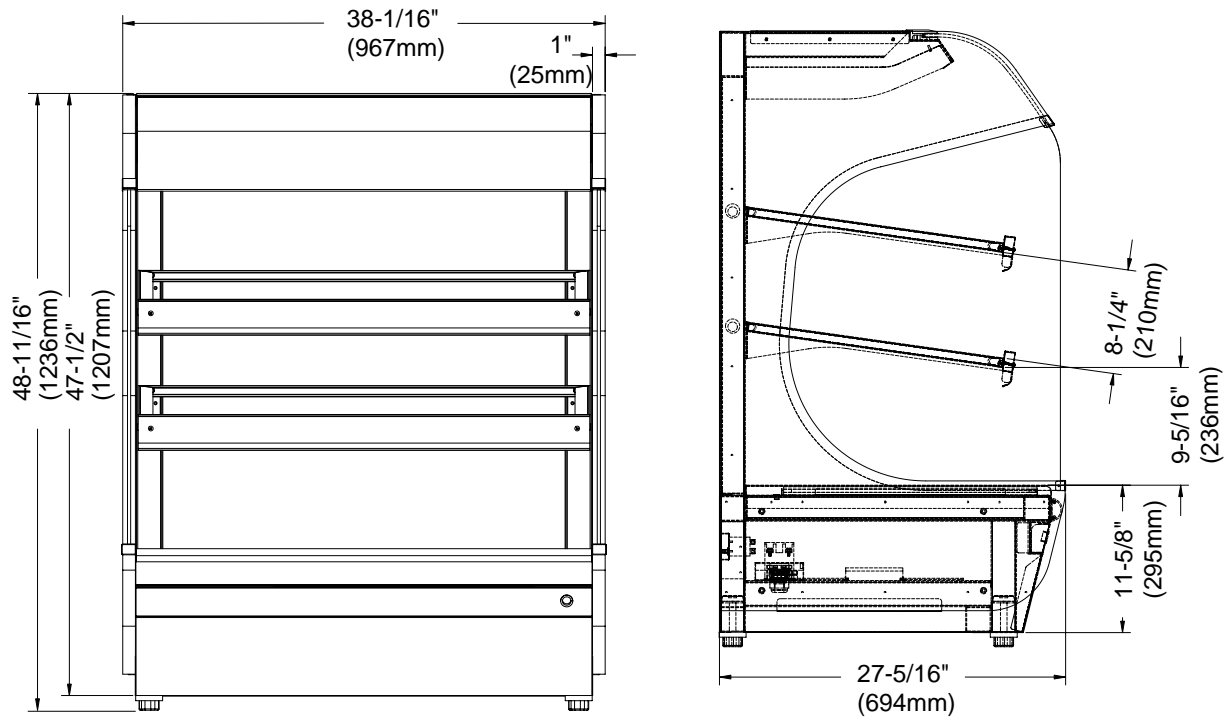

EXTERIOR DIMENSIONS: H x W x D	
48-11/16" x 38-1/16" x 27-5/16" (1236mm x 967mm x 694mm)	
Top two shelves:	32-7/8" x 20" (835mm x 508mm)
W x D	- spaced at 7-3/8" (187mm) centers
Bottom shelf:	33-3/8" x 23" (848mm x 584mm)
	- spaced at 7-7/8" (200mm) centers

INSTALLATION REQUIREMENTS
Unit must be installed level. It must not be installed in any area where it may be affected by steam, grease, dripping water, high temperatures, or any other severely adverse conditions. In order to maintain NSF standards, stationary models must be sealed at bottom by NSF approved sealant, or equipped with casters, or 4" (102mm) legs.

CLEARANCE REQUIREMENTS
4" (102mm) at back of unit

ELECTRICAL					
VOLTAGE	PHASE	CYCLE/HZ	AMPS	kW	CORD SUPPLIED WITHOUT PLUG
208-240	1	50/60	12.5	3.0	 NEMA 6-20P 20A-250V RECOMMENDED
MUST BE ON ITS OWN 20 AMP CIRCUIT					
380	CONTACT FACTORY				

PRODUCT CAPACITY
52 lb (23.6 kg) MAXIMUM
EACH SHELF
Eight (8) chicken boats with dome cover

WEIGHT
NET 335 lb (152 kg)
SHIP 595 lb (270 kg)
CRATE DIMENSIONS: 65" x 46" x 36" (1651mm x 1168mm x 914mm)
(H x W x D) DOMESTIC SHIPMENTS ONLY

OPTIONS & ACCESSORIES	
<input type="checkbox"/> Cabinet	5002703
<input type="checkbox"/> Casters, 3" (76mm)	CONTACT FACTORY
<input type="checkbox"/> Legs, 6" (152mm)	5205