

ITM-72

ISLAND TAKEOUT MERCHANDISER



- HALO HEAT . . . a controlled, uniform heat source provides a gentle, even heat source for longer product holding life.
- Freestanding, self-service merchandiser designed to provide quality hot packaged foods with minimum labor costs.
- Lighted display maximizes visual merchandising — promotes impulse sales.
- Over 15 square feet of heated surface.
- Heat source radiates from the base and the upper canopy with adjustable temperature settings.
- Concealed thermostat and light controls are easily accessible to the operator.
- Curved glass on two sides adds to the clean streamlined look.
- Bumpers on two sides of the unit provide extra protection against damage from shopping carts.
- End mounted stainless steel wire racks maximize merchandising opportunity.
- Available with black painted base as standard, optional stainless steel, or can be color matched and painted.

18 gauge, non-magnetic stainless steel heated well is controlled by one (1) ON/OFF adjustable thermostat with a range of 1 through 10 and includes an indicator light. The overhead canopy is supported by two stainless steel side supports, enclosing eight (8) bulbs and two (2) heating elements. These elements are controlled with one (1) ON/OFF adjustable thermostat with a range of 1 through 10 which includes an indicator light. Controls are located in a concealed area behind the perimeter panel.

Self-service heated well is 4-1/2" (114mm) deep and must be used with prepackaged foods only. A shallow shelf insert is included as standard. The island base features bumpers on two sides and is furnished with four (4) 3" (76mm) casters which swivel and include brakes. Stainless steel wire racks extend from two ends of the unit to maximize merchandising opportunity.

MODEL ITM-72: Island Take-out Merchandiser, 72" wide



ADDITIONAL FEATURES & OPTIONS

- Exterior base panel options
 - ➔ Specify on order.
 - Stainless steel
 - Custom color



Control panel

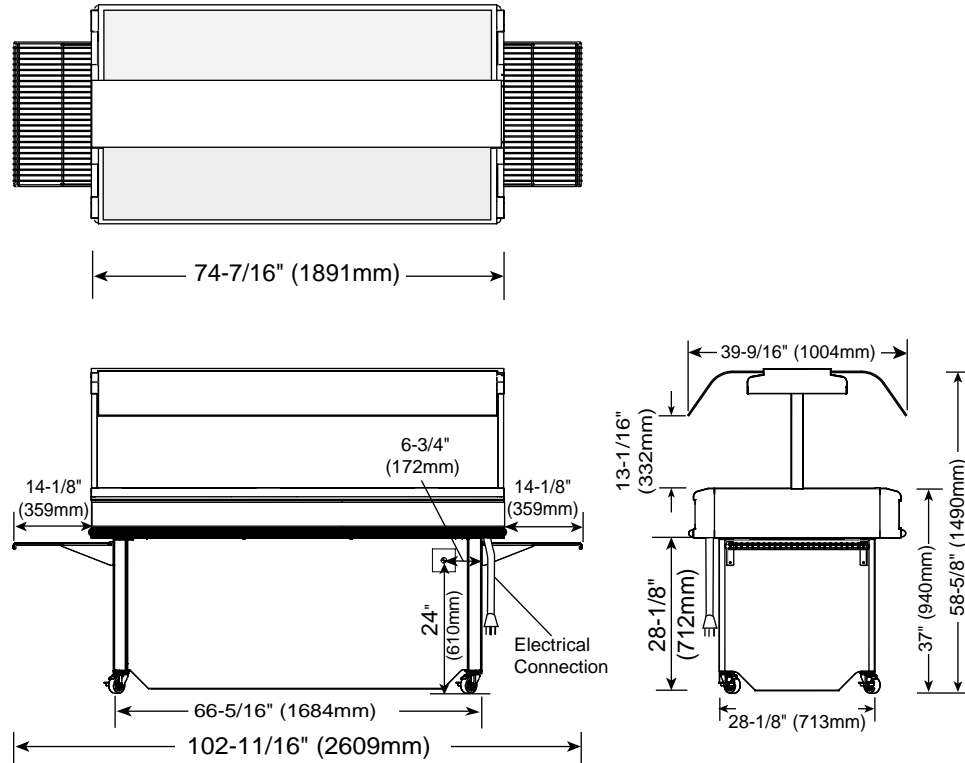

WEIGHT	
	ITM-72
NET	677 lb (307 kg)
SHIP	845 lb (383 kg)
CRATE	67" x 93" x 52"
DIMENSIONS: (1702mm x 2362mm x 1321mm) (H x W x D) DOMESTIC SHIPMENTS ONLY	

INSTALLATION REQUIREMENTS
Unit must be installed level, and must not be installed in any area where it may be affected by steam, grease, dripping water, high temperatures, or any other severely adverse conditions.
CLEARANCE REQUIREMENTS
None.

OPTIONS & ACCESSORIES	
Exterior Base Panels	
<input type="checkbox"/> Custom color	P147
<input type="checkbox"/> Stainless steel side, 2 REQUIRED	1000429
<input type="checkbox"/> Stainless steel end, 2 REQUIRED	5000215

DIMENSIONS: H x W x D	
EXTERIOR: (WITH WIRE SIDE RACKS) 58-5/8" x 102-11/16" x 39-9/16" (1490mm x 2609mm x 1004mm)	
HEATED WELL DIMENSIONS: (L x W x D) 69-5/16" x 26-15/16" x 4-1/2" (1760mm x 684mm x 114mm)	

ELECTRICAL						
VOLTAGE	PHASE	CYCLE/HZ	AMPS	kW	CORD & PLUG INCLUDED	
120/208-240V	at 208	1	60	25.4	5.3	 NEMA 14-50P 120/250 V 50 AMP Plug
	at 240	1	60	26.3	6.3	
PROVIDED WITH A LOAD CENTER AND CIRCUIT BREAKERS FOR POWER INPUT WITHIN BASE						

PRODUCT CAPACITY
75 lbs (34 kg) MAXIMUM
VOLUME MAXIMUM: 47 QUARTS (44 LITERS)
CHICKEN PACKAGES WITH DOMES - CAPACITY: 21
DOME PACKAGE SIZE: APPROX. 7" x 10" (178mm x 254mm)